

Servo kits ILM

Structural integrated drive engineering leading to highest power density by superb freedom of design integrated drive technology



With the stator-rotor installation kits of the ILM series RoboDrive offers solutions for structurally integrated drive engineering.

The RoboDrive technology provides the highest power density at maximum torque range and overload capability in a compact design. The flexible concept offers solutions for a variety of demanding drive applications. On request alternative voltage levels, increased speeds and customized torque adaptations are realizable.

The implementation of customer-specific solutions to achieve a compact and thermally optimized design is supported by detailed documentation, engineering services based on the RoboDrive-development expertise.

Key features:

- Frameless motors for highest design flexibility
- Hollow shaft capability
- Low voltage 12 V - 48 V
- Highest torque density and dynamics
- Redundant windings available
- Low thermal losses by excellent copper filling - orthocyclic single pole winding
- Thermally optimized actuator design by structural integration
- Weight and installation space optimized drive system design based on load profile analysis
- High control quality by high bandwidth and lowest harmonics

Basic data

	ILM 25x 04	ILM 25x 08	ILM 38x 06	ILM 38x 12	ILM 50x 08	ILM 50x 14	ILM 70x 10	ILM 70x 18	ILM 85x 04	ILM 85x 13	ILM 85x 23	ILM 85x 26	ILM 115x 25	ILM 115x 50
Power P [W]	60	60	95	165	155	180	270	275	405	430	410	410	735	760
Rated torque T_r^* [Nm]	0,024	0,048	0,1	0,2	0,27	0,5	0,74	1,25	0,43	1,43	2,3	2,6	5,4	11,2
Peak torque T_{max} @ 20% deviation from linearity [Nm]	0,1	0,2	0,4	0,7	0,9	1,4	2,3	4	1,2	4,5	7,3	8,3	12,2	40
Rotation speed n_{max}^{**} [rpm]	24.000	12.000	9.000	8.000	5.500	3.500	3.500	2.100	9.000	2.900	1.700	1.500	1.300	650
Diameter D [mm]	25	25	38	38	50	50	69	69	85	85	85	85	115	115
Length L [mm]	9,2	13,6	13,5	20,5	14,6	21	20,3	28,2	15	24,2	34,2	37,6	35,5	64,9
Weight m [g]	16	29	52	86	86	135	230	340	200	370	550	590	1.200	2.170
Rotor inertia J [kgcm ²]	0,0023	0,004	0,01	0,02	0,049	0,086	0,21	0,34	0,28	0,61	0,98	1,15	3,65	7,90

* When installed in aluminium, highly dependent on installation situation. ** Theoretical no-load rotation speeds at $U_n = 48V$. Variations can arise from operation with different inverters. Higher rotation speeds or change of the voltage level can be achieved by changing the connection scheme.

Performance characteristics (interconnection star-serial)

	ILM 25x 04	ILM 25x 08	ILM 38x 06	ILM 38x 12	ILM 50x 08	ILM 50x 14	ILM 70x 10	ILM 70x 18	ILM 85x 04	ILM 85x 13	ILM 85x 23	ILM 85x 26	ILM 115x 25	ILM 115x 50
Rated voltage U_r [V]	24	24	24	48	48	48	48	48	48	48	48	48	48	48
Rated current I_r [A]	2,8	2,8	5	5	4,8	5	7	7	11	11	11	11	20	20
Copper losses P_{r,T_r} and 20°C [W]	4	4	7	9	10	17	18	24	13	20	30	30	38	65
Torque constant k_T @ 20°C [Nm/A]	0,008	0,016	0,021	0,046	0,057	0,098	0,11	0,18	0,04	0,13	0,21	0,24	0,27	0,56
Motor constant k_M @ 20°C [Nm/A]	0,012	0,023	0,039	0,067	0,084	0,121	0,177	0,255	0,121	0,328	0,426	0,495	0,88	1,41
Terminal resistance R_{TT} @ 20°C [mΩ]	500	748	363	530	552	800	470	655	138	210	320	323	125	240
Terminal inductance L_{TT} * [μH]	170	285	250	375	720	820	800	1.350	120	470	890	920	525	1.170
Number of pole pairs	7	7	7	7	10	10	10	10	10	10	10	10	15	15
Max. efficiency η [%]	87	86	88	87	88	87	90	90	92	92	92	91	93	92

* All quantities so marked can be adjusted by varying the connection scheme.

Mounting dimensions

	ILM 25x 04	ILM 25x 08	ILM 38x 06	ILM 38x 12	ILM 50x 08	ILM 50x 14	ILM 70x 10	ILM 70x 18	ILM 85x 04	ILM 85x 13	ILM 85x 23	ILM 85x 26	ILM 115x 25	ILM 115x 50
Outer diameter stator D_{js8} [mm]	25	25	38	38	50	50	69	69	85	85	85	85	115	115
Diameter PCB G [mm]	24,2	24,2	36,6	36,6	48,2	48,2	67,4	67,4	83,4	83,4	83,4	83,4	112,4	112,4
Diameter winding head g [mm]	23,8	23,8	36	36	47,6	47,2	66	66	81	81	81	81	110	110
Length stator B [mm]	11,9	16,4	16,2	23,3	17,2	23,7	23,7	31,6	18,4	27,6	37,6	41	39,5	68,9
Hollow shaft diameter rotor d_{H7} [mm]	11,6	11,6	18	18	30	30	42	42	52	52	52	52	74	74
Length stator l [mm]	6,3	9,7	8,1	16,2	9,9	16,1	12,7	20,7	7,1	15,7	25,1	27,2	27,1	54,2
Air gap s [mm]	0,15	0,15	0,4	0,4	0,15	0,15	0,4	0,4	0,4	0,4	0,4	0,4	0,6	0,6

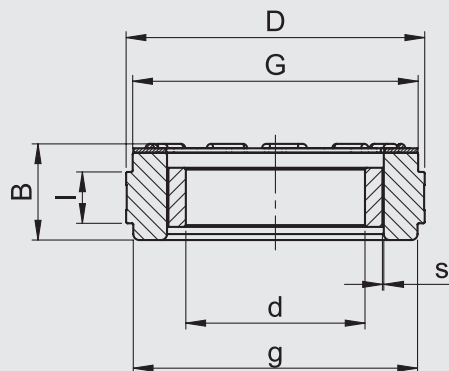

RoboDrive is a brand of the TQ-Group
 TQ-Systems GmbH | Mühlstr. 2 | 82229 Seefeld | Germany
 Tel.: +49 8153 9308-0 | Fax: +49 8153 4223
 info@robodrive.com | www.robodrive.com

